

Bent axis hydraulic motors

M
Series

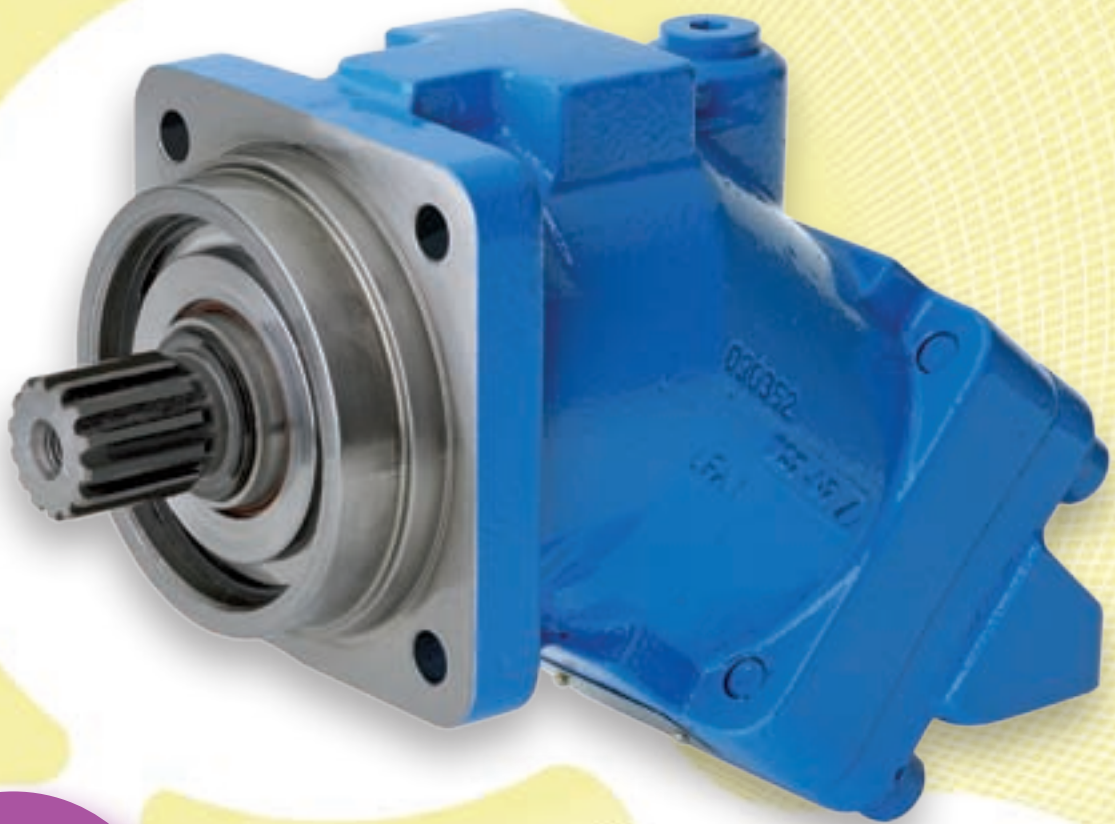

**HYDRO
LEDUC**

Contents

- Definition and main applications of hydraulic motors, advantages of HYDRO LEDUC motors 1
- Operating conditions of motors. 2
- Determining the right motor 3
- Range and characteristics 4
- Efficiency curves 5
- Order code system 6
- Dimensions 7 - 15
- Flushing valve 16
- Speed sensor 17
- ATEX certification 18
- Installation and start-up recommendations. 19
- Other HYDRO LEDUC product lines 21

M series motors

HYDRO LEDUC hydraulic motors of the M series are of bent axis design, with an angle of 40°. They combine high performance and reduced size envelope:

- global efficiency of over 90% (guaranteed in most applications);
- suitable for use at operating speeds between 50 and 8,800 rpm;
- optimized weight and size.

Available in displacements from 18cc to 108cc, M motors are suitable for all the main fixed and mobile applications. They are designed for use in either closed or open loop systems. To ensure the best service life from your motors, please take care to follow the installation and start-up recommendations (see pages 2 and 19).

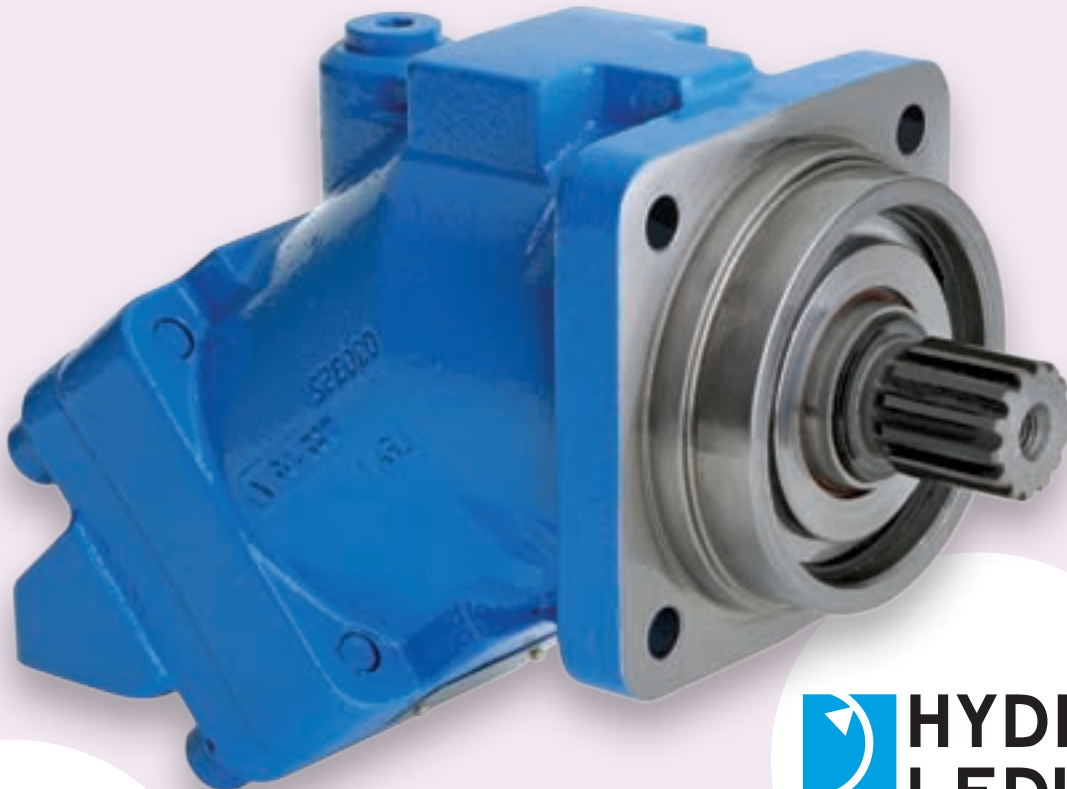

HYDRO LEDUC
Head Office & Factory
BP 9
F-54122 AZERAILLES (FRANCE)
Tél. +33 (0)3 83 76 77 40
Fax +33 (0)3 83 75 21 58



HYDRO LEDUC also manufactures a range of semi-integrated (plug-in) motors: the MSI series. Literature on request or on our website : www.hydroleduc.com

Advantages of M series motors

■ Definition of function

Hydraulic motors transform hydraulic flow into rotating speed and hydraulic pressure into mechanical torque.
Motor rotating speed is proportional to the flow which is supplied to it.
Torque produced is proportional to the hydraulic pressure the motor receives.

■ Main applications of hydraulic motors

Typical applications are those requiring high torque within a small size.
The hydraulic motor is essential for rotations where:
- mechanical solutions are complex or even impossible,
- electrical or pneumatic power sources are not available,
- environments are dangerous (i.e. risk of explosion or extreme temperatures).

■ Advantages of HYDRO LEDUC motors

All structural components are made from similar materials resulting in consistent thermal expansion and exceptional reliability.

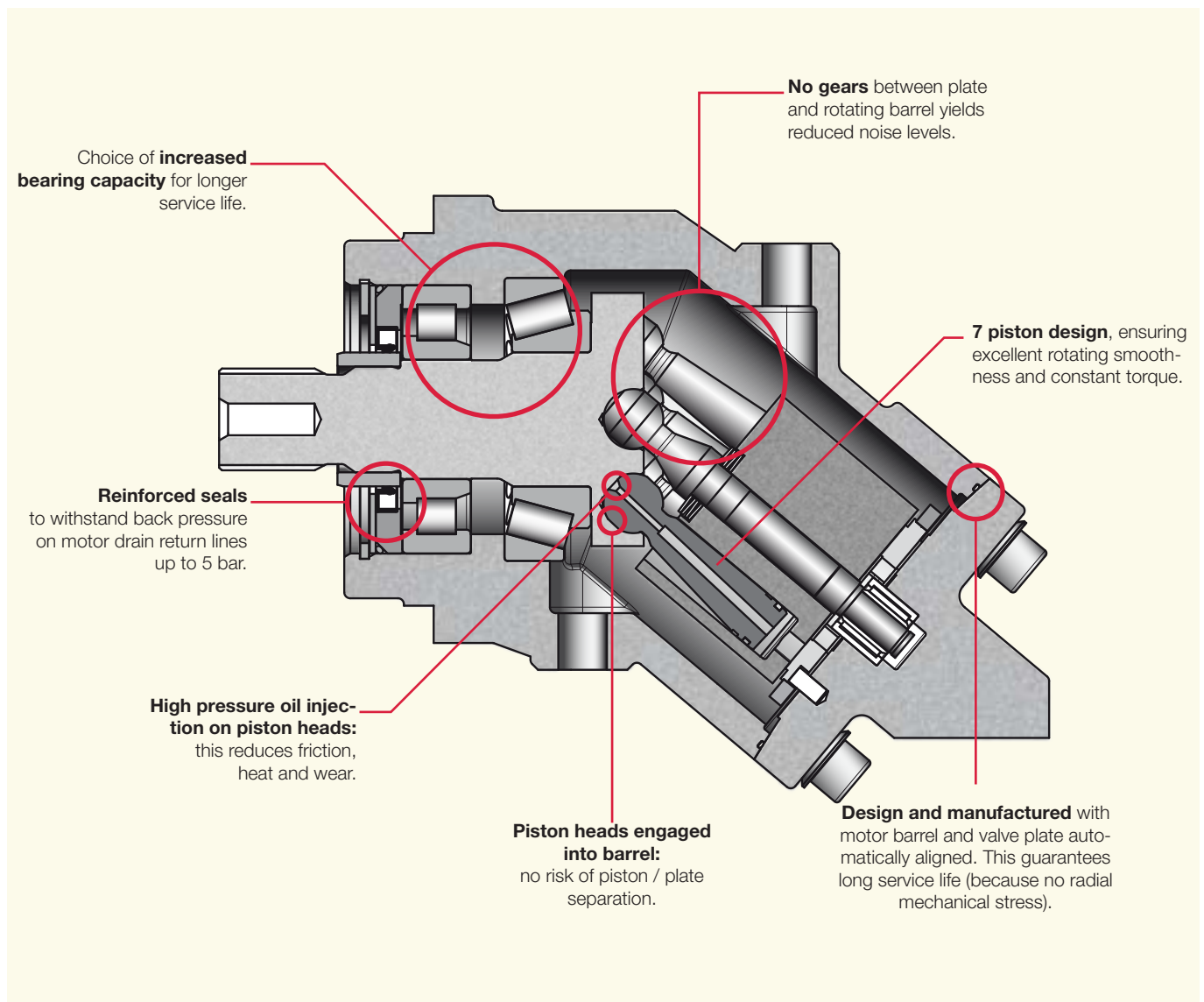

Operating conditions of M series motors

Hydraulic fluid

HYDRO LEDUC motors are designed to be powered with mineral based hydraulic fluid. Using other fluids is possible but may require a modified motor. Please contact us with details of fluid.

Recommended viscosity:

- Ideally : between 15 and 200 cSt;
- Maximum range: between 5 and 1600 cSt.

Filtration of hydraulic fluid

The service life of the motors depends greatly on the quality and the cleanliness of the hydraulic fluid.

We recommend minimum cleanliness as follows:

- NAS 1638 class 9
- SAE class 6
- ISO/DIS 4406 class 18/15

Direction of rotation

The motors rotate clockwise or counter-clockwise depending on the direction of hydraulic flow entering the motor.

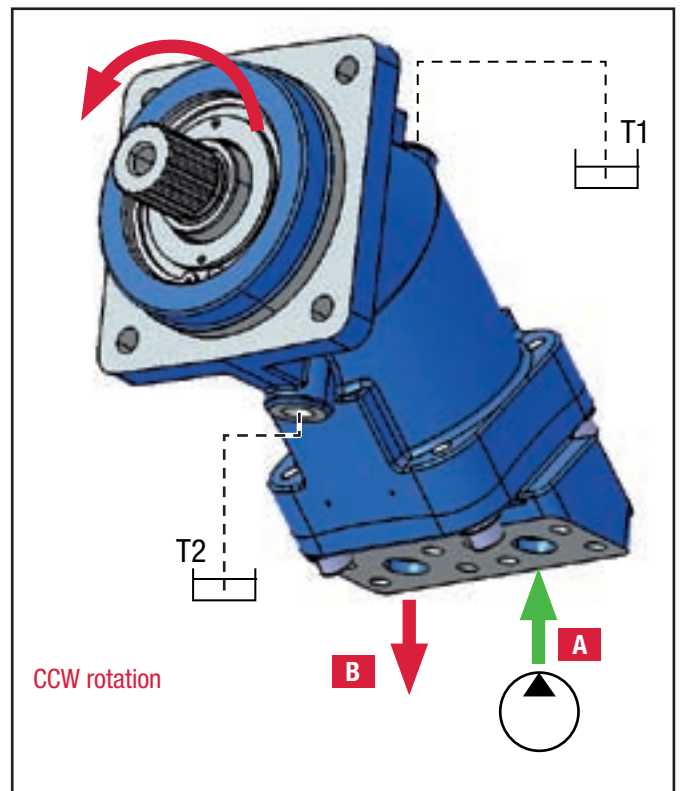
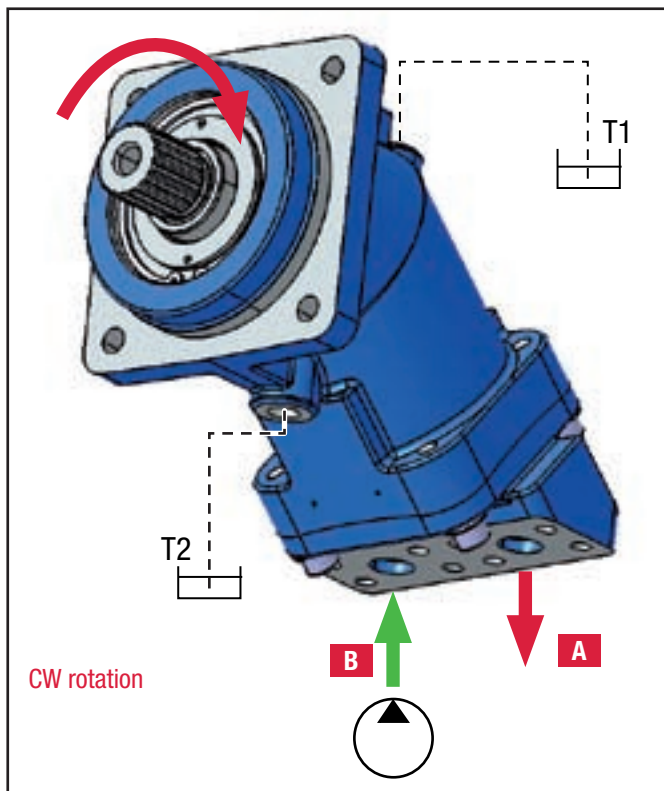

Drain pressure

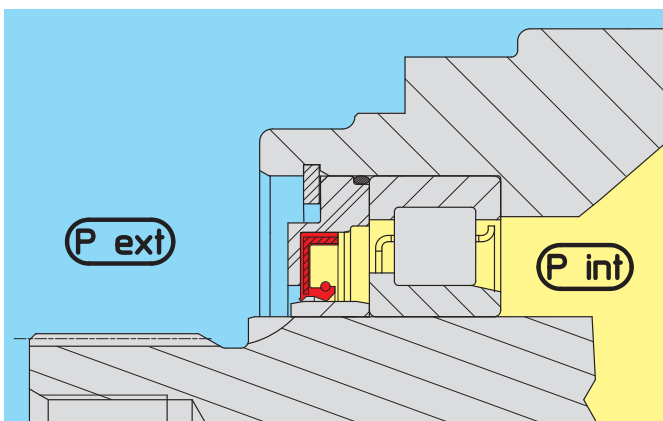

It is essential to drain the motor, T1 or T2, to avoid excessive pressures on the shaft seal.

Maximum acceptable internal pressure depends on motor rotating speed.

However, following these guidelines will avoid problems during operation:

- maximum internal pressure (**P int**) regardless of rotating speed (continuous): 4 bar (60psi);
- maximum internal pressure (**P int**) regardless of rotating speed (peak): 5.5 bar (80psi);
- minimum pressure in the motor housing: must be greater than ambient (external) pressure (**P ext**).

Determination M series motors

How to determine the correct motor for your application

Calculations using usual mechanical units:

- N = rotating speed in rpm
- C = torque in N.m
- P = pressure supplied by the generator (hydraulic pump), in bar
- ΔP = pressure difference between A and B, in bar
- Disp. = displacement in cc
- Q = flow in litres per minute
- η = efficiency (%)

1. Torque supplied by the hydraulic motore

$$\text{Theoretical torque} = \frac{\text{Disp.} \times \Delta P}{20 \pi} = C_{th}$$

$$\text{Torque } C = C_{th} \times \eta_{\text{motor}}$$

For example: a 50cc motor with a ΔP of 250 bar will supply a theoretical torque of : 200 N.m.
Average global efficiency of the motor is 90%, actual torque is thus: 180 N.m

2. Rotating speed of the motor

The rotating speed of the hydraulic motor depends on the flow Q which goes through it, and on the displacement of the motor.

$$N = \frac{Q}{\text{Disp.}} \times 1000$$



test bench for motors

Example

- ① Motor
- ② Variable displacement pump
- ③ Pressure relief valve
- ④ Valve
- ⑤ Hydraulic motor
- ⑥ Winch and load

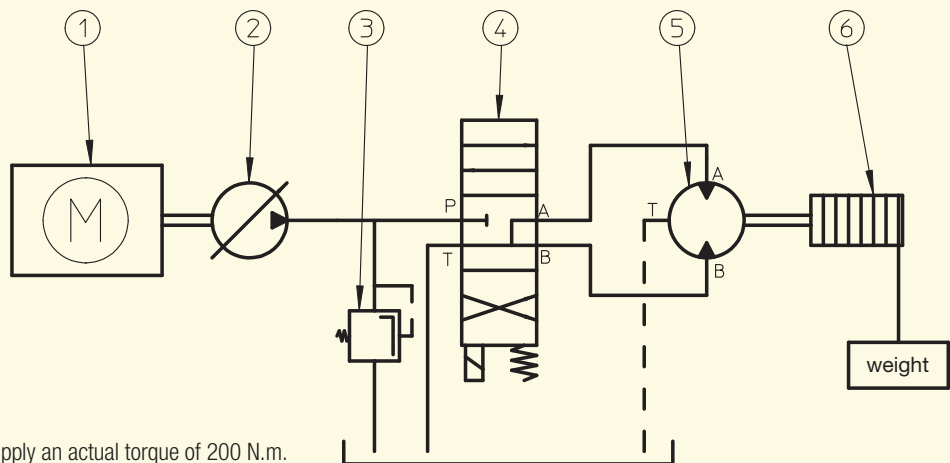

The receiving organ (winch) ⑥ needs to rotate at $N = 400$ rpm and supply an actual torque of 200 N.m.

The hydraulic pump ① is capable of operating at pressure P up to 350 bar.

1. Calculating the displacement of the hydraulic motor:

$$C_{th} = \frac{\text{Disp.} \times \Delta P}{20 \pi} \text{ thus Disp. } \mathbf{Cy = 35.9 \text{ cc}}$$

..... → In the YDRO LEDUC range, choose a motor with a displacement of **32 cc** or **41 cc**.

2. Calculating the flow Q which the pump needs to supply:

$$N = \frac{Q}{\text{Disp.}} \times 1000 \text{ thus } \mathbf{Q = 14.36 \text{ l/min}}$$

Corresponding flow :
- for **32 cc** motor, $Q = 12.8 \text{ l/min}$
- for **41 cc** motor, $Q = 16.4 \text{ l/min}$

Range and characteristics M series motors



Characteristics of the M series motors

M series motors are suitable for intensive long duty requirements. Designed for both mobile and industrial installations.

Typical applications are:

- vehicle transmissions;
- high power crushers;
- forestry equipment;
- heavy duty winches...

These motors are built to suit all applications to ISO standard 3019/2.

Displacement (cc)	continuous max. speed ⁽¹⁾ (rpm)	Intermittent max. speed ⁽¹⁾ (rpm)	Max. flow absorbed (l/mn)	Torque bar (m.N/bar)	Torque at 350 bar (m.N)	Motor max./min. temperature* (°C)	Max. allowable pressure continuous / peak (bar)	weight (kg)
18	8000	8800	144	0.28	98	-25 / 110	400 / 450	5.5
25	6300	6900	158	0.4	140	-25 / 110	400 / 450	11.5
32	6300	6900	202	0.5	175	-25 / 110	400 / 450	11.5
41	5600	6200	230	0.65	227	-25 / 110	400 / 450	11.5
50.3	5000	5500	252	0.8	280	-25 / 110	400 / 450	18
63	5000	5500	315	1	350	-25 / 110	400 / 450	18
80.4	4500	5000	362	1.27	445	-25 / 110	400 / 450	23
90	4500	5000	378	1.42	497	-25 / 110	400 / 450	23
108.3	4000	4400	435	1.7	595	-25 / 110	400 / 450	23

* for wider extreme temperatures, please contact us.

(1) for higher speeds, please contact us.

For special fluids, please contact us.

4

Acceptable forces applied to motor shaft

Fr : radial force measured at mid point of length of shaft.

Fa : axial force which tends to push the shaft inwards.

Displacement	cc	18	25	32	41	50.3	63	80.4	90	108.3
Fr	N	4000	6000	6500	7000	4000	5000	6500	6700	7000
Fa	N/bar*	20	27	30	40	40	50	60	67	80

* differential pressure between A and B.

For other forces, please contact us.

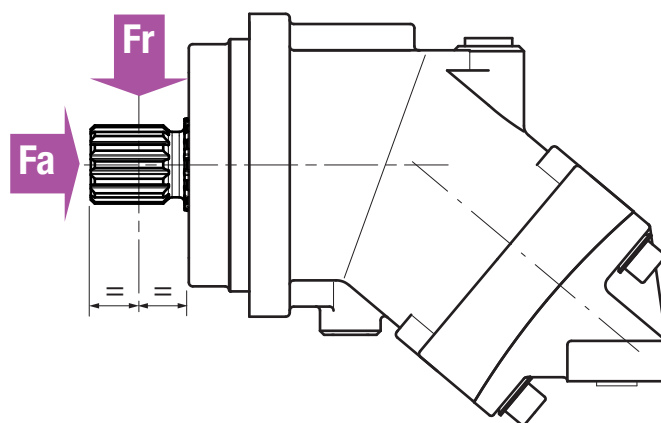

Efficiency M series motors

■ Efficiency of motors $f(\text{displacement})$

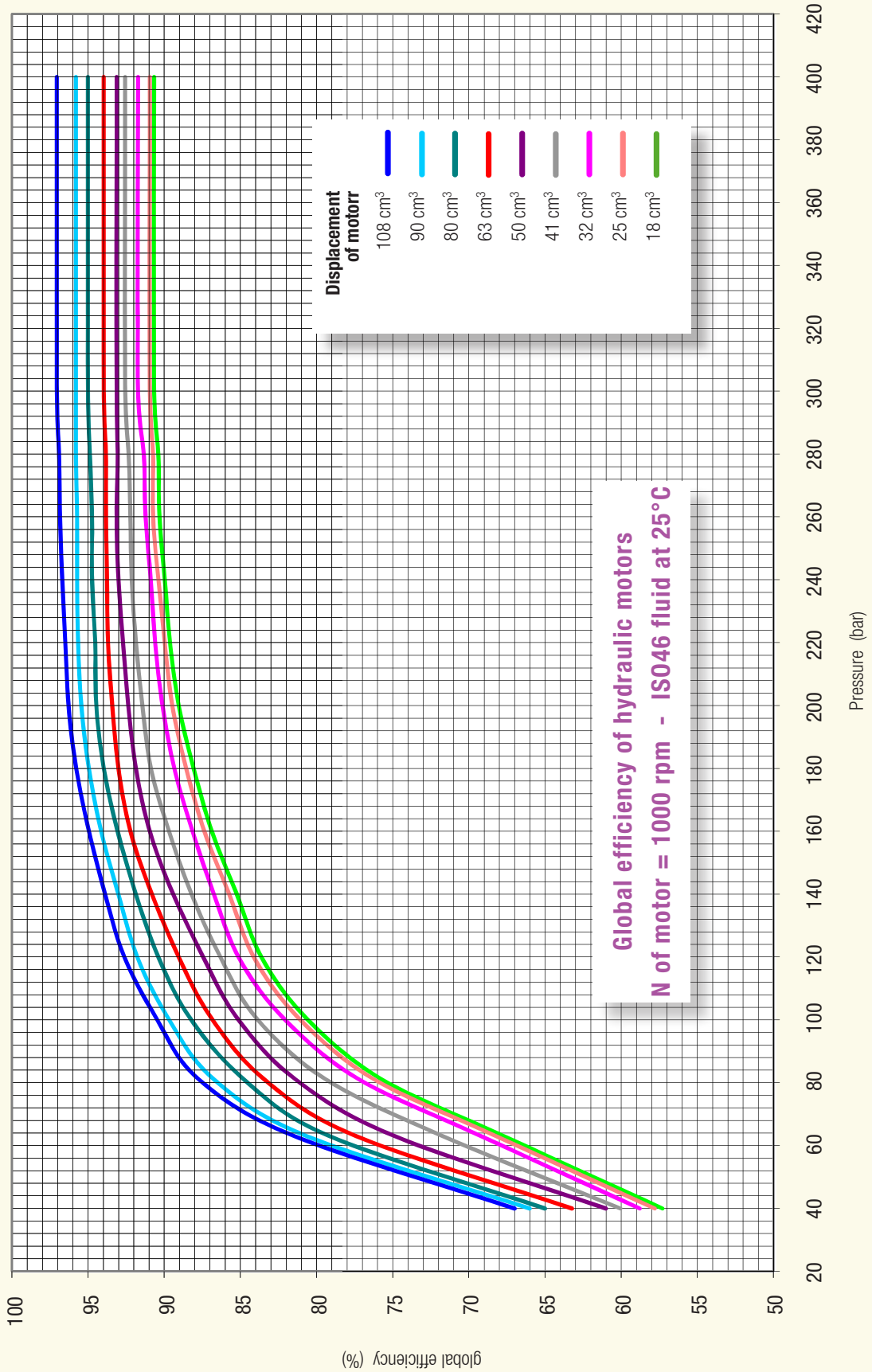

Order code system M series motors

Order code system for M type motor

M	...	A	M2
01	02	03	04	05	06	07	08	09

To obtain the code for your motor, complete the different parameters 02, 04, 05, 07, 08 and 09 in the table on the left, according to the options you require (see table below).

01	Motor	Motor											M
02	Displacement				18	25	32	41	50	63	80	90	108
03	Mounting flange				ISO 3019-2 4 bolt							A	
04	Shaft end	DIN 5480 splined	W25	W25	W30	W30	W30	W30	W40	W40	W40	W1	
			-	-	W25	-	W35	W35	-	-	-	W2	
		DIN 6885 keyed	∅ 25	∅ 25	∅ 30	∅ 30	∅ 30	∅ 30	∅ 40	∅ 40	∅ 40	D1	
			-	-	-	-	∅ 35	∅ 35	-	-	-	D2	
05	Inlet ports A and B	SAE flange ports	bottom	0	-	-	●	●	●	●	●	●	L0
			rear	0	-	●	●	●	●	●	●	●	M0
			side	0	-	●	●	●	●	●	●	●	N0
		Threaded	side	1	-	●	●	●	●	●	●	●	N1
			side	0	●	●	●	●	●	●	●	●	Q0
			side	1	-	●	●	●	●	●	●	●	Q1
			rear	0	●	●	●	●	●	●	●	●	P0
06	Drain ports T1 and T2	-		2	2	2	2	2	2	2	2	M2	
07	Suitable for use of speed sensor	yes										1	
		no										0	
08	Speed sensor	yes										1	
		no										0	
09	Valves	without										SV	
		with flushing valve										VB	

Suitability for valves:
 - no0
 - compatible with flushing valve1

Dimensions

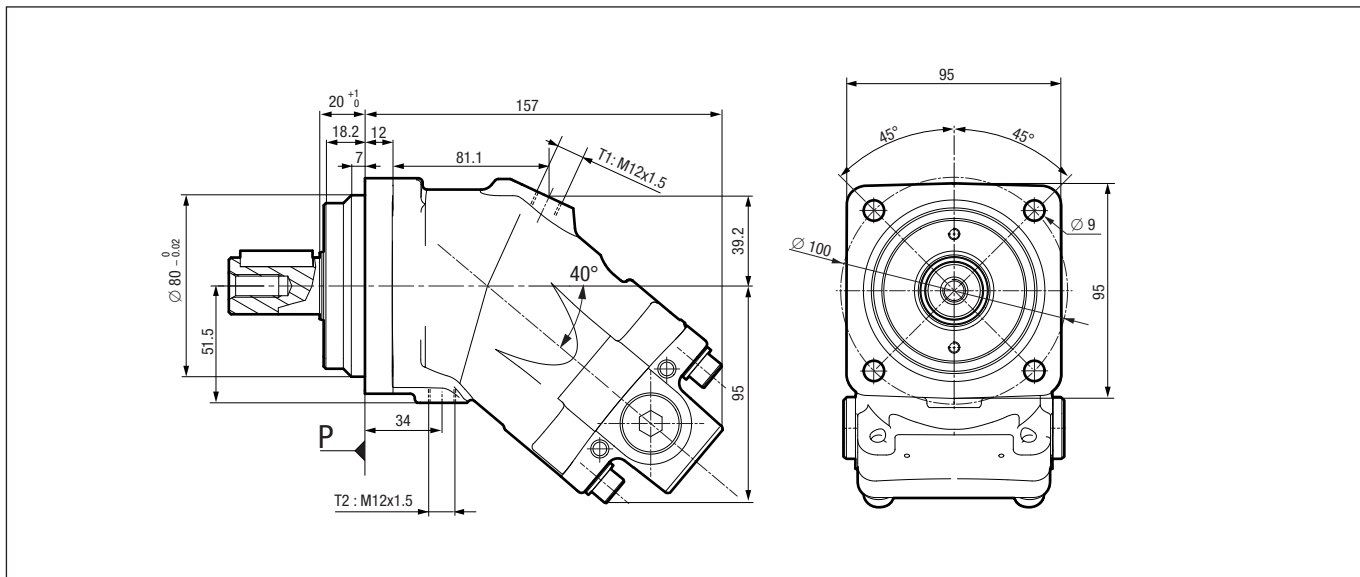

Shaft end

W1 Splined shaft DIN 5480
W 25 x 1.25 x 30 x 19 x 9 g

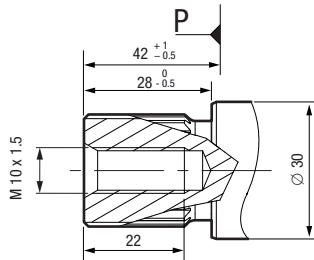

D1 Cylindrical keyed shaft $\varnothing 25$ DIN 6885
AS 8 x 7 x 32

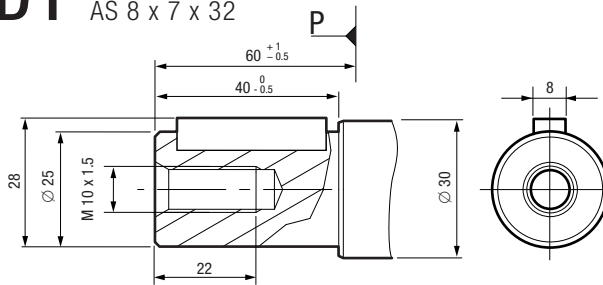

Inlet ports

Q0 Side threaded ports A et B

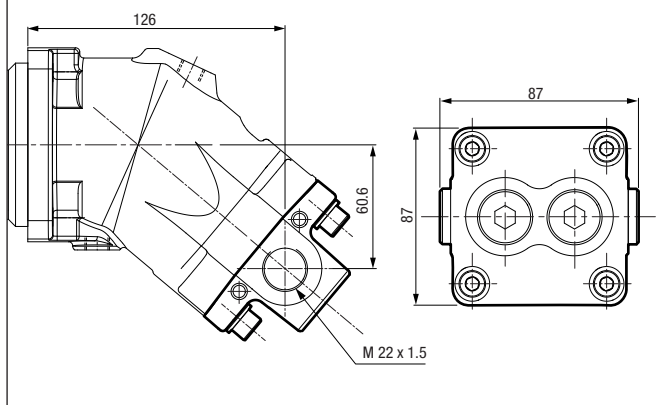

P0 Rear threaded ports A and B

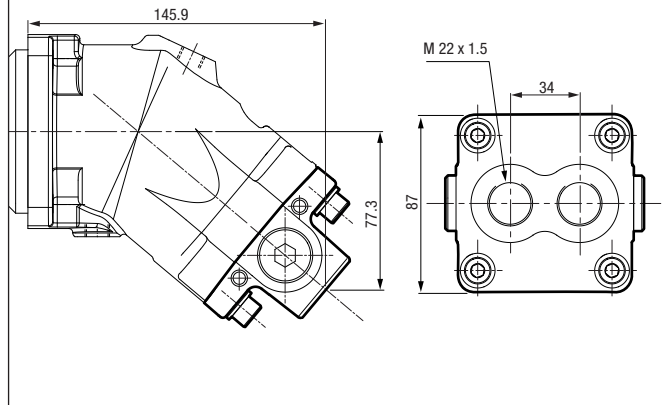

Dimensions

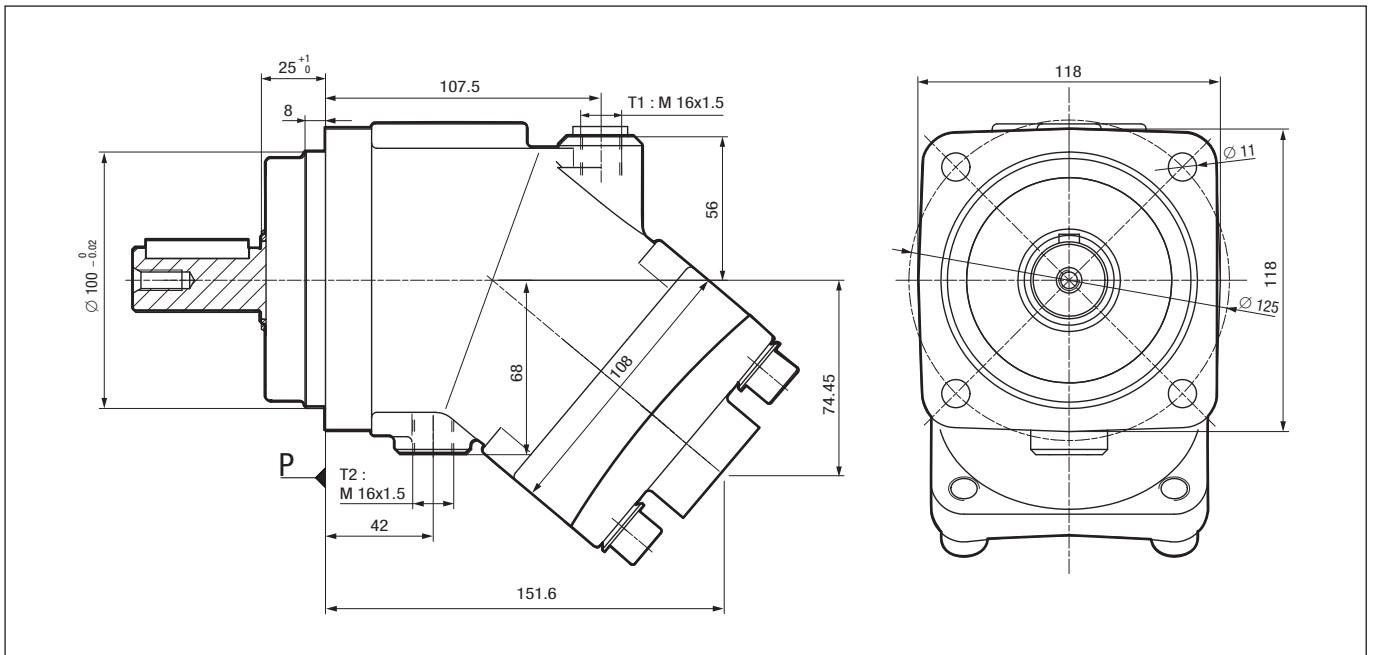

Shaft end

W1 Splined shaft DIN 5480
W 25 x 1.25 x 30 x 19 x 9 g

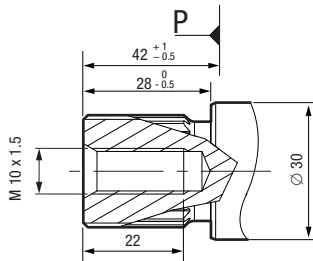

D1 Cylindrical keyed shaft $\varnothing 25$
DIN 6885 AS 8 x 7 x 40

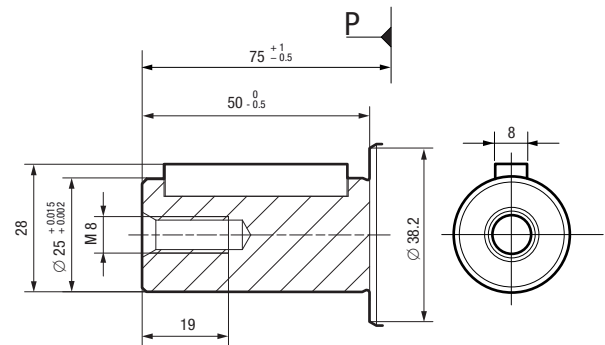

Inlet ports

P0 Rear threaded ports A and B

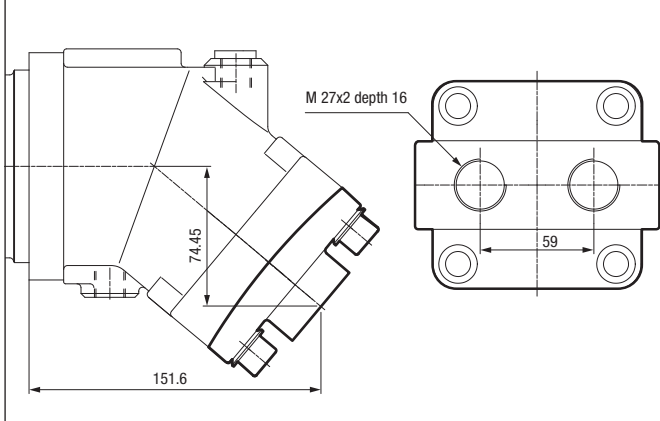

Inlet ports

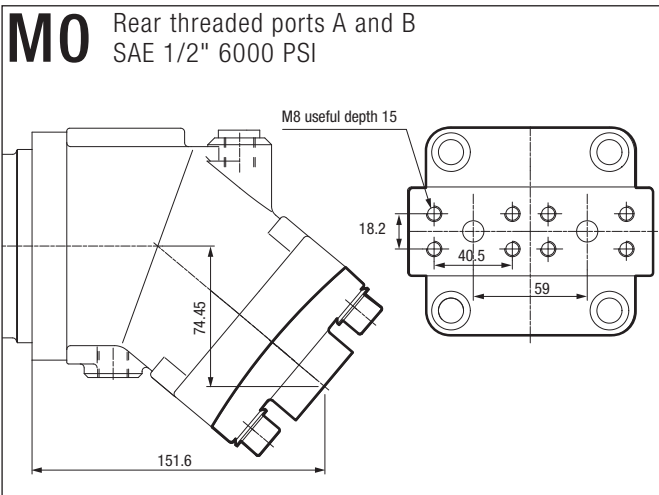
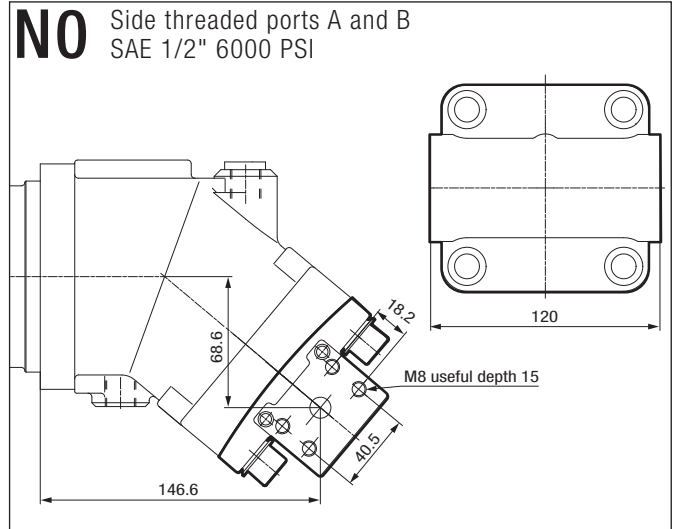
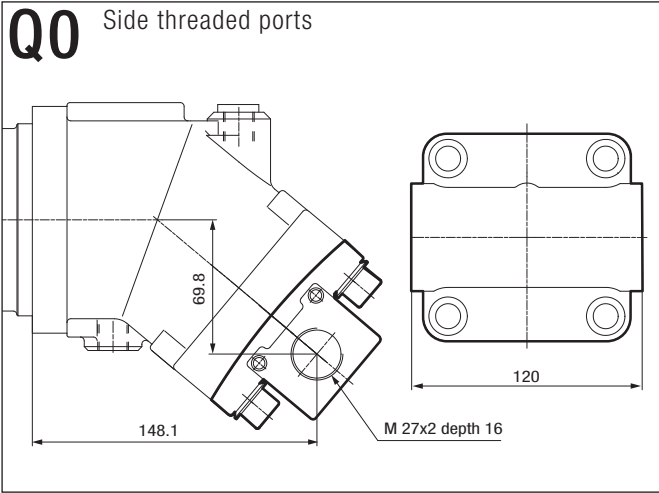

Dimensions

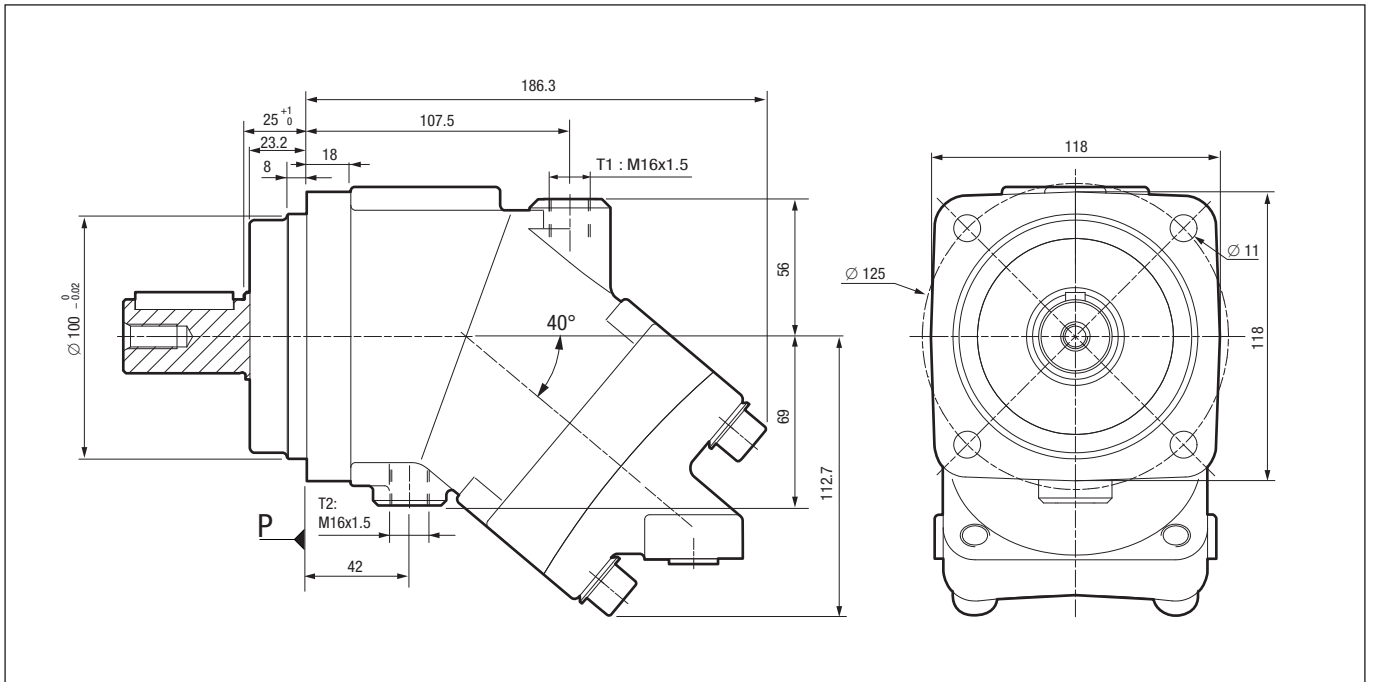

Shaft end

W1 Splined shaft DIN 5480
W 30 x 2 x 30 x 14 x 9 g

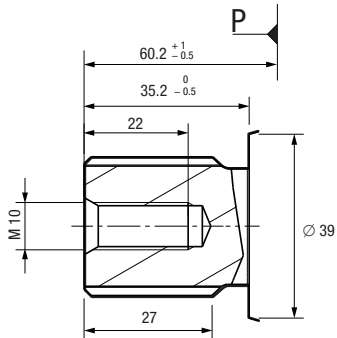

W2 Splined shaft DIN 5480
W 25 x 1.25 x 30 x 18 x 9 g

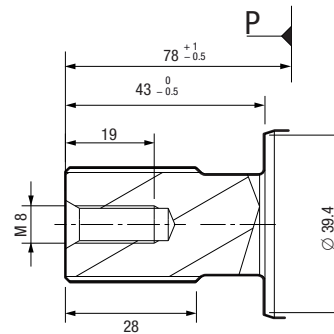

D1 Cylindrical keyed shaft $\varnothing 30$ DIN 6685
AS 8 x 7 x 40

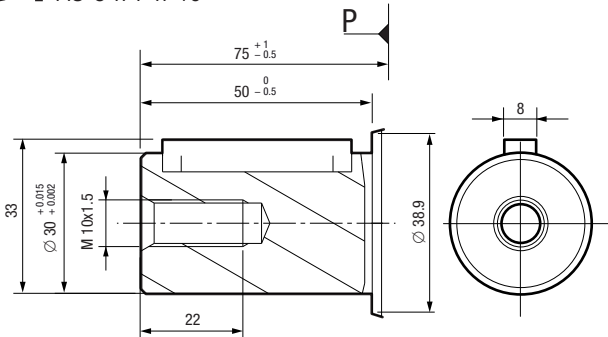

Inlet ports

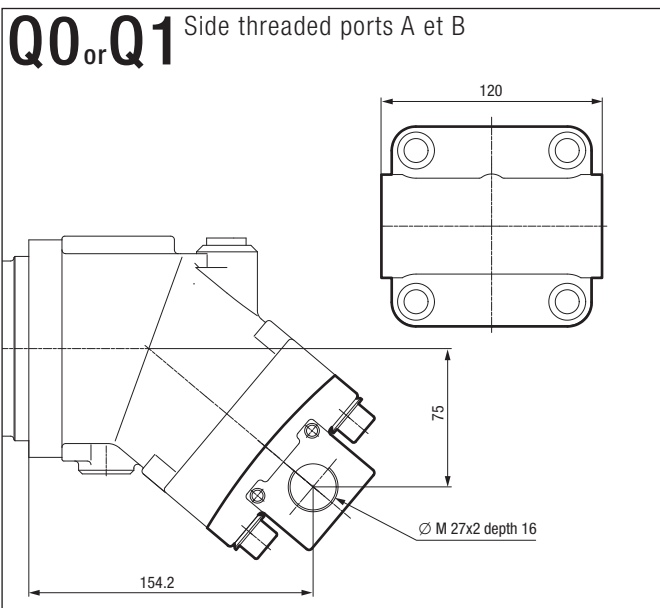
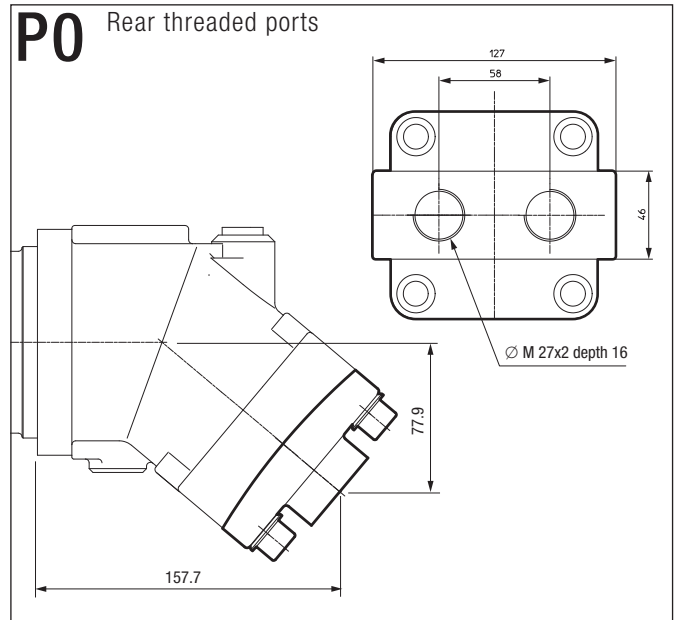
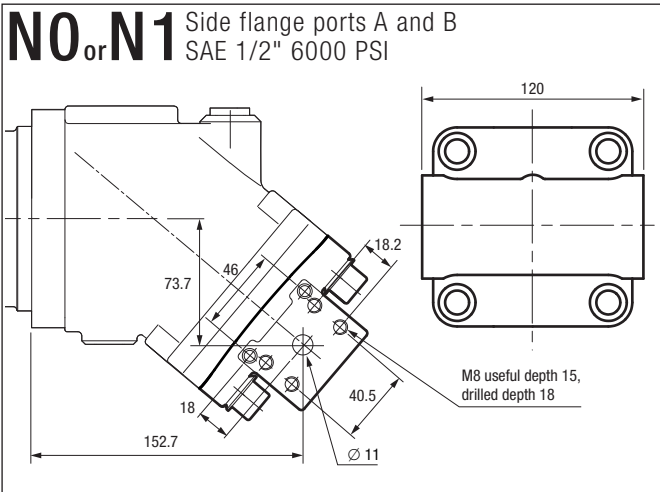
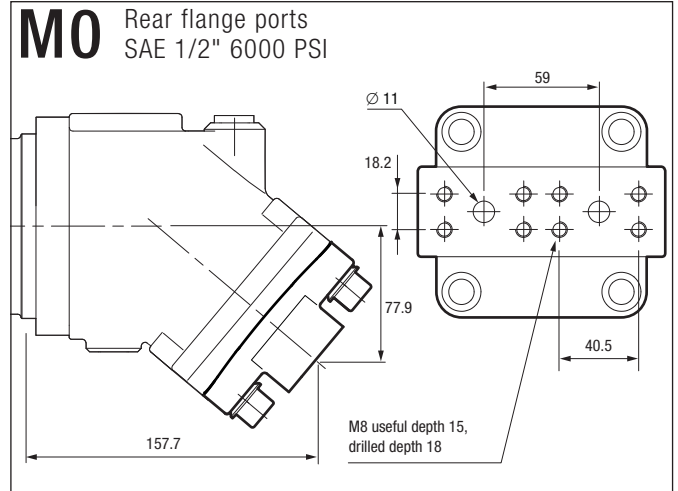
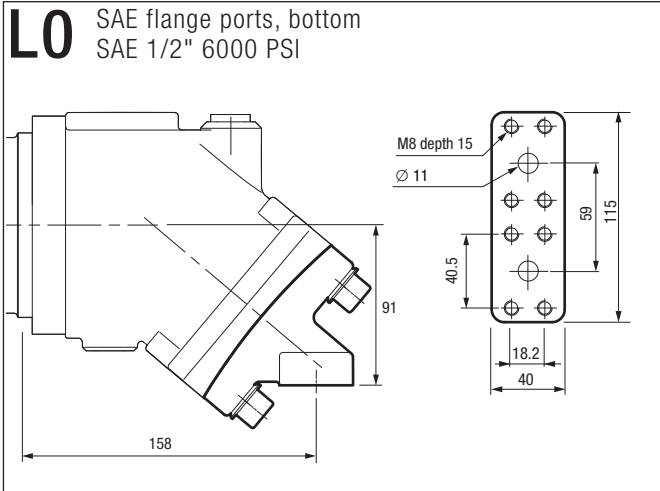

Dimensions

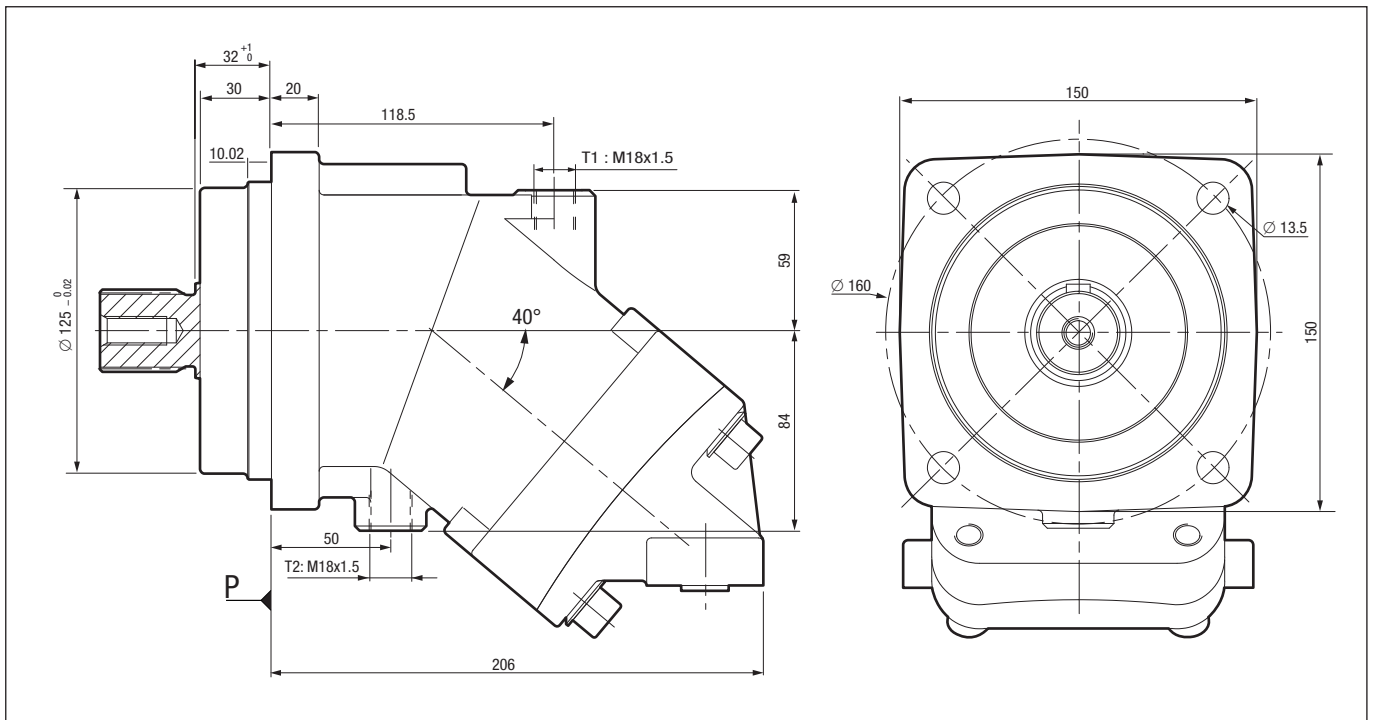

Shaft end

12

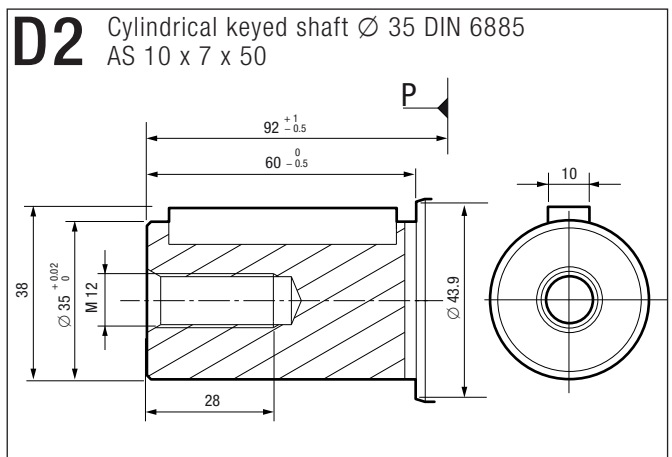
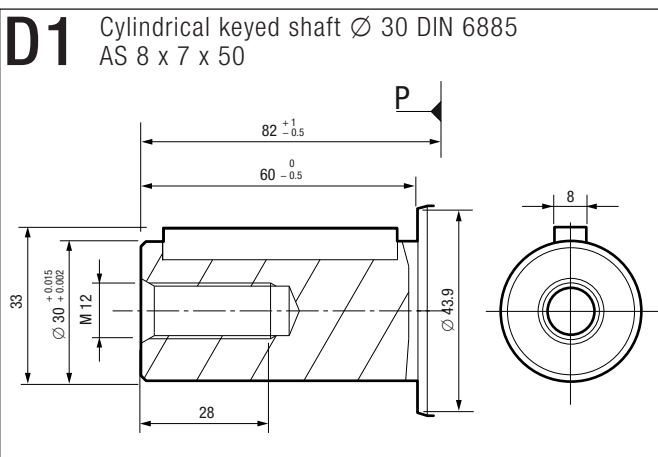
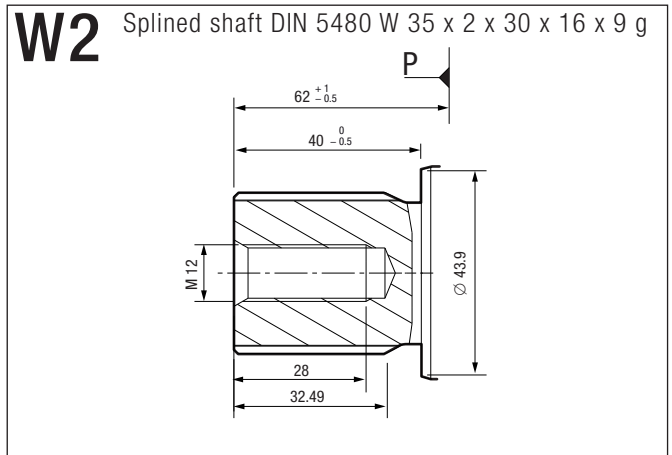
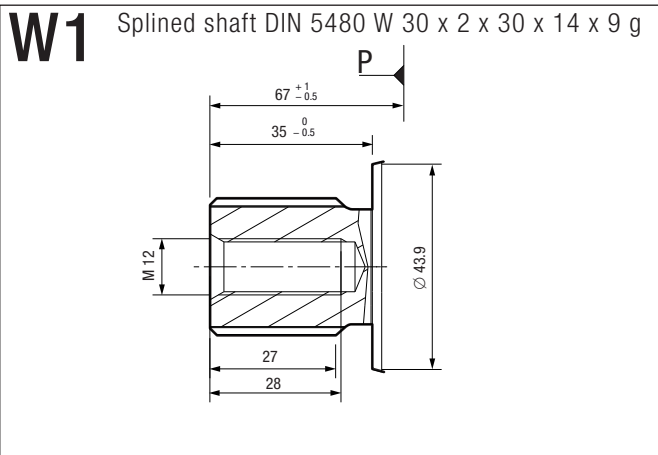

Inlet ports

L0 SAE flange ports, bottom
SAE 3/4" 6000 PSI

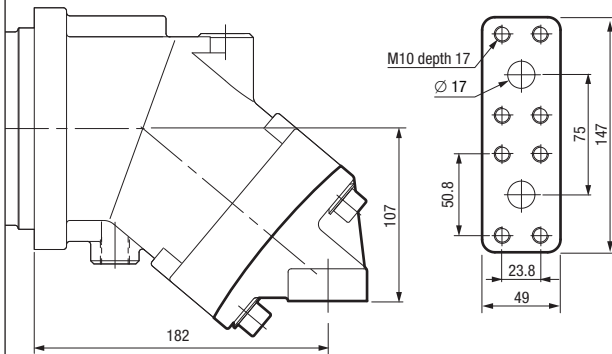

M0 SAE flange ports, rear
SAE 3/4" 6000 PSI

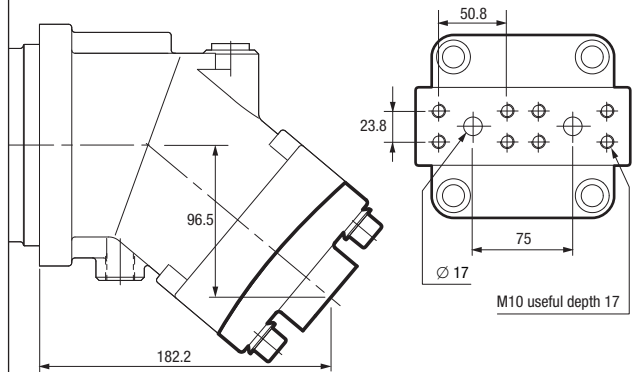

N0 or N1 SAE flange ports, side A and B
SAE 3/4" 6000 PSI

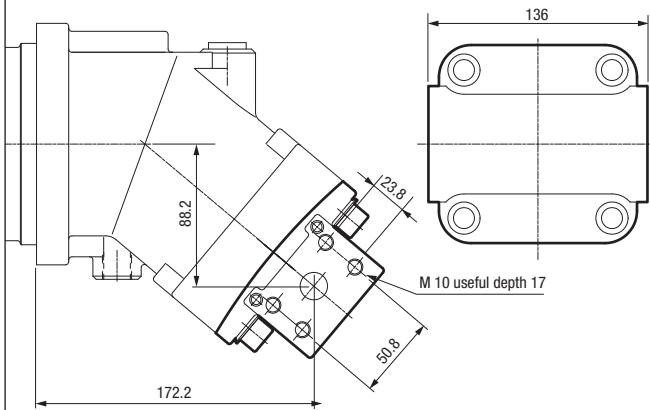

P0 Side threaded ports

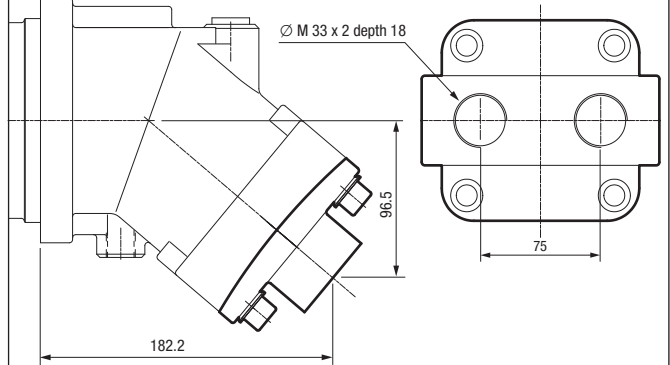

Q0 or Q1 Side threaded ports A and B

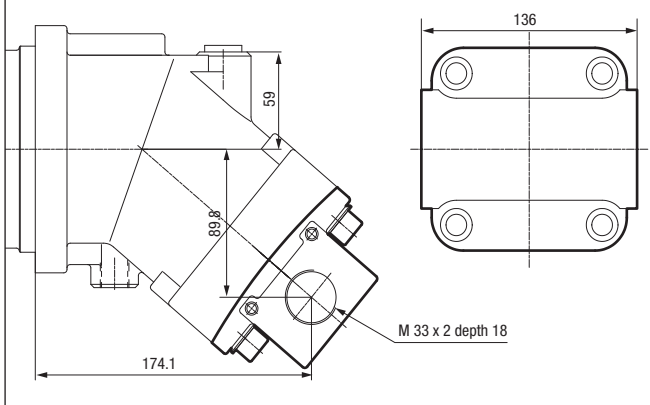

Dimensions

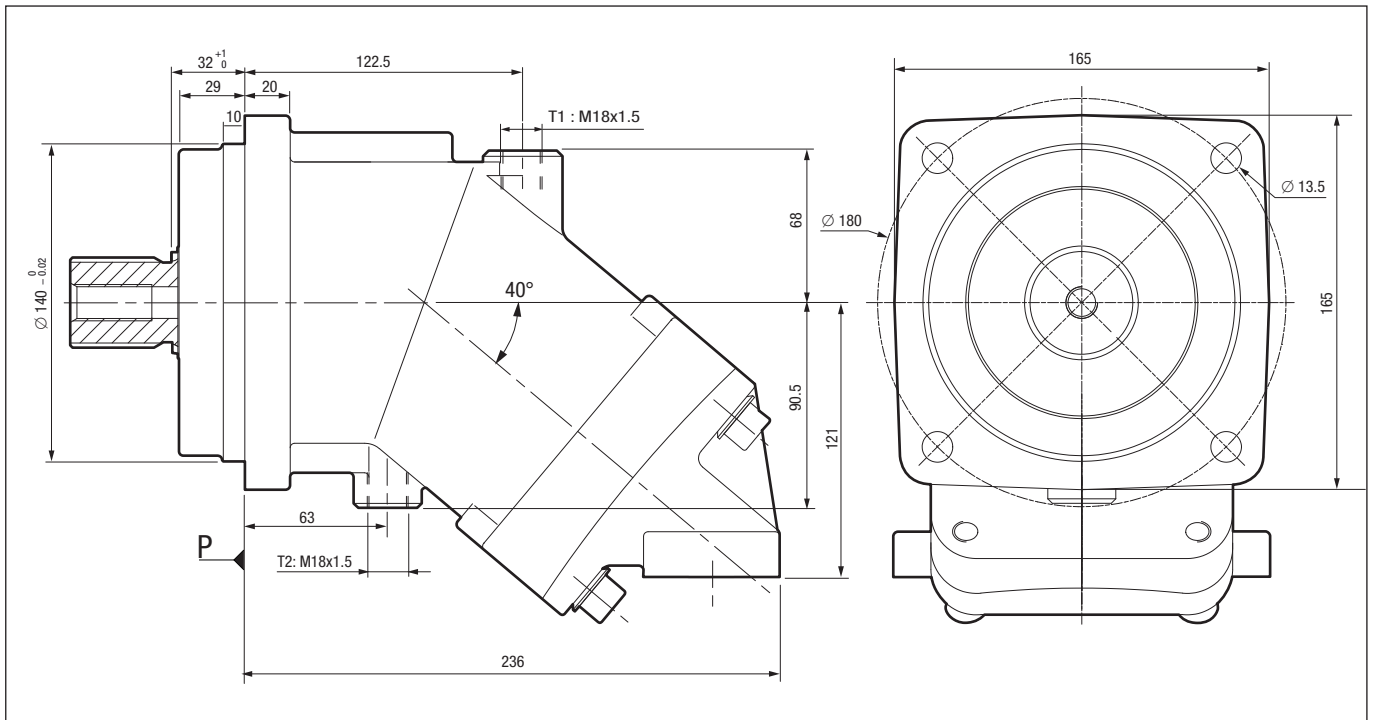

Shaft end

W1 Splined shaft DIN 5480
W 40 x 2 x 30 x 18 x 9 g

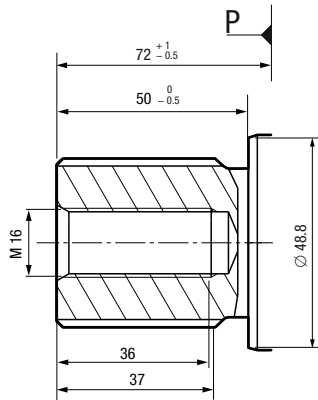

D1 Cylindrical keyed shaft $\varnothing 40$ DIN 6885
AS 12 x 8 x 56

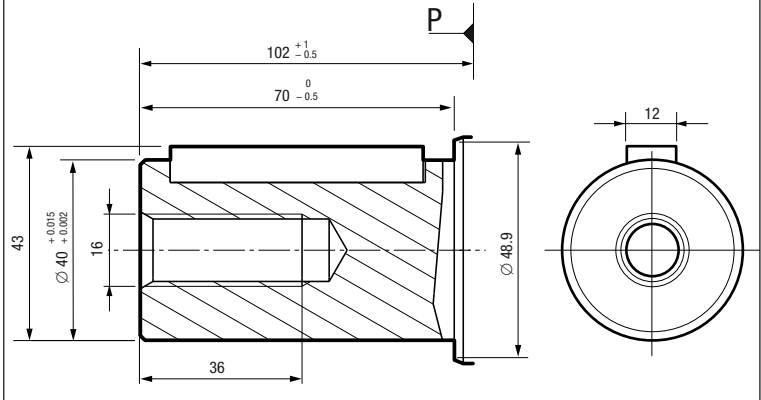

Inlet ports

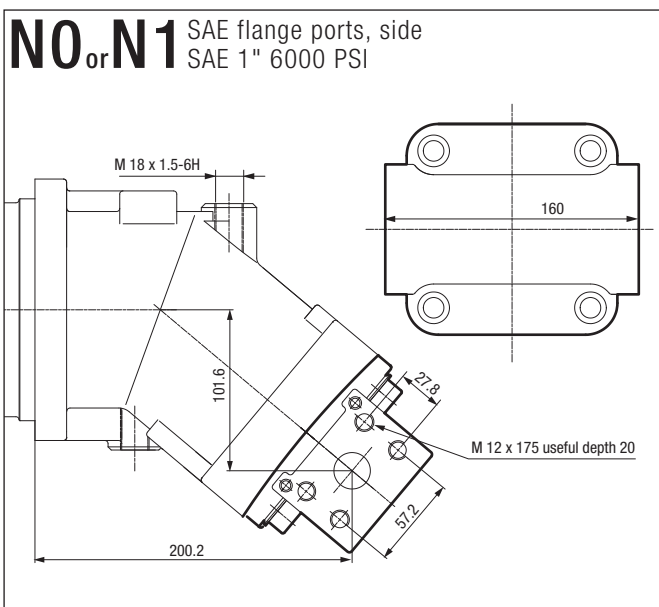
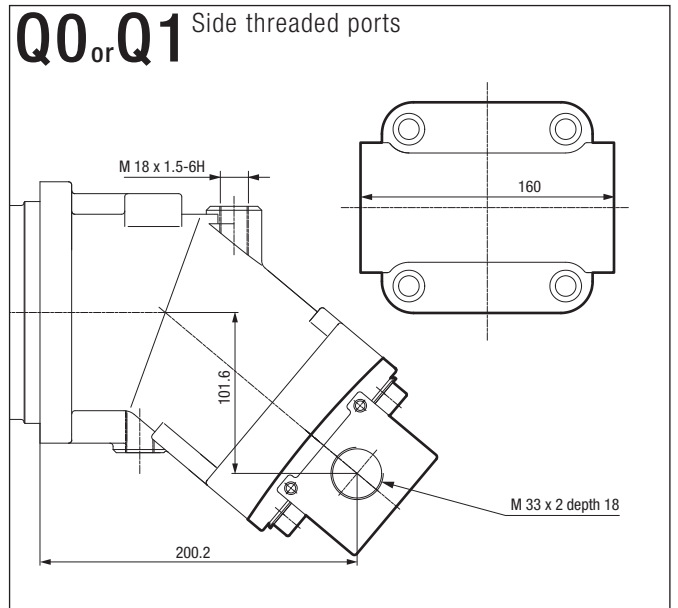
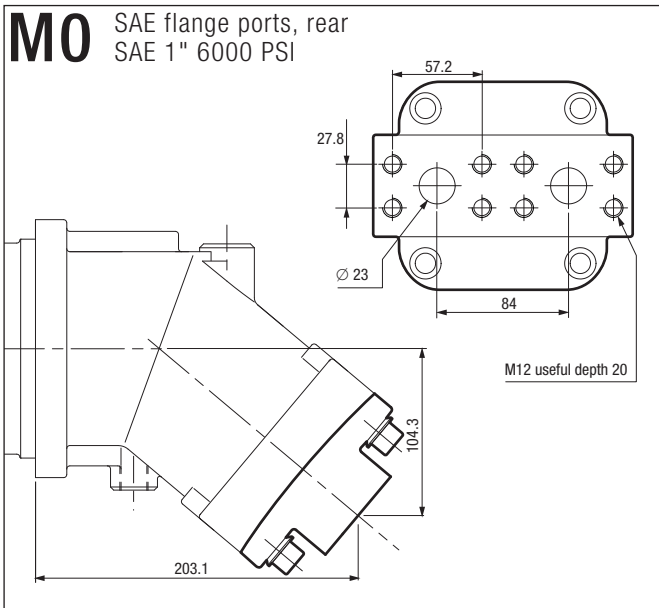
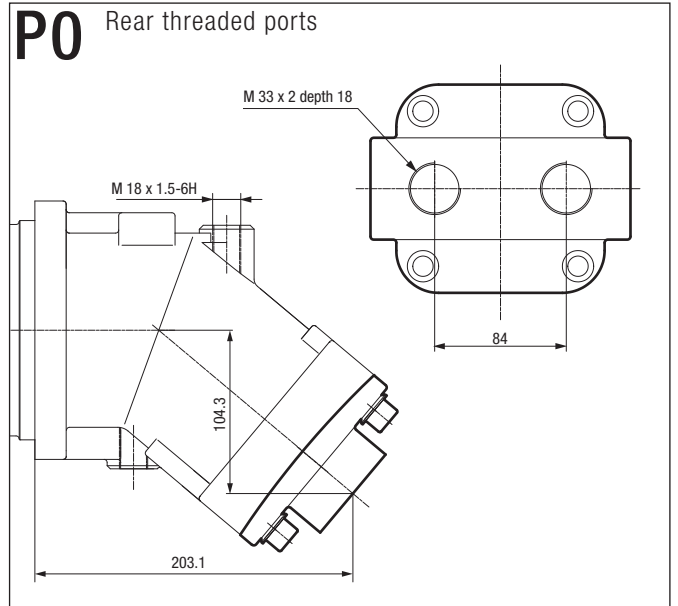
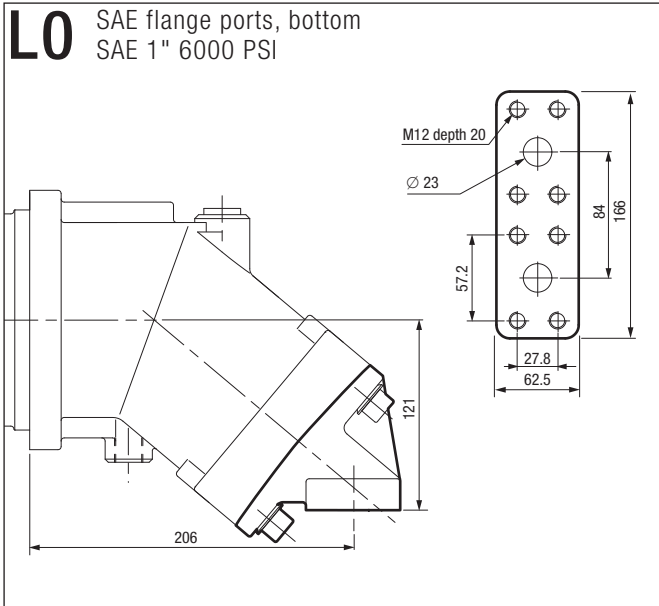

Flushing and resupply valve

Used to create flow to cool the motor. This valve is essential for all intensive uses of motors and contributes to long service life, particularly in closed loop transmission applications.

The valve takes some hydraulic fluid internally from the return connection port (low pressure) and reinjects it into the motor housing. This is then evacuated via the motor drain line.

The flushing and resupply valve is only available for use on motors with side ports (N1 or Q1 in order code).

HYDRO LEDUC reference: VBS 091180.

Schematic:

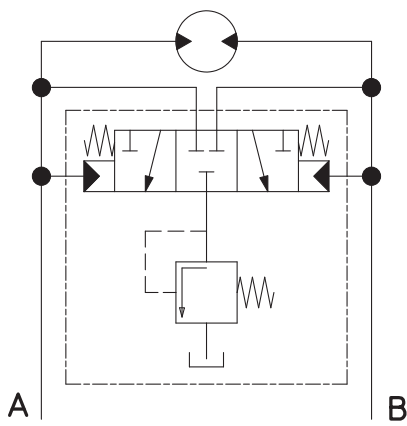

Dimensions:

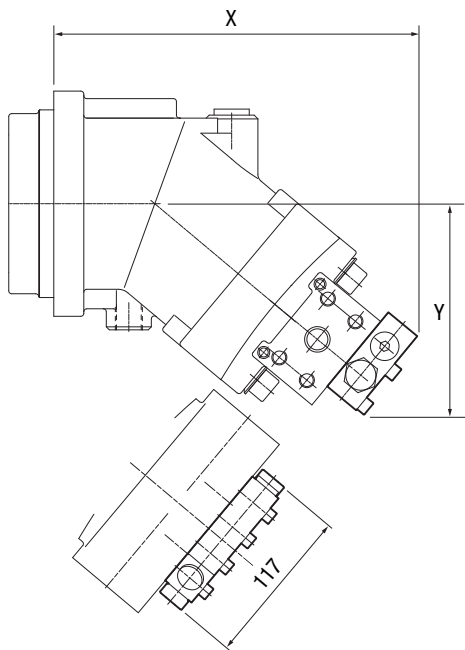

Motor displacement (cc)	X (mm)	Y (mm)
32 - 41	123	215
50 - 63	141	240
80 - 90 - 108	157.6	272.3

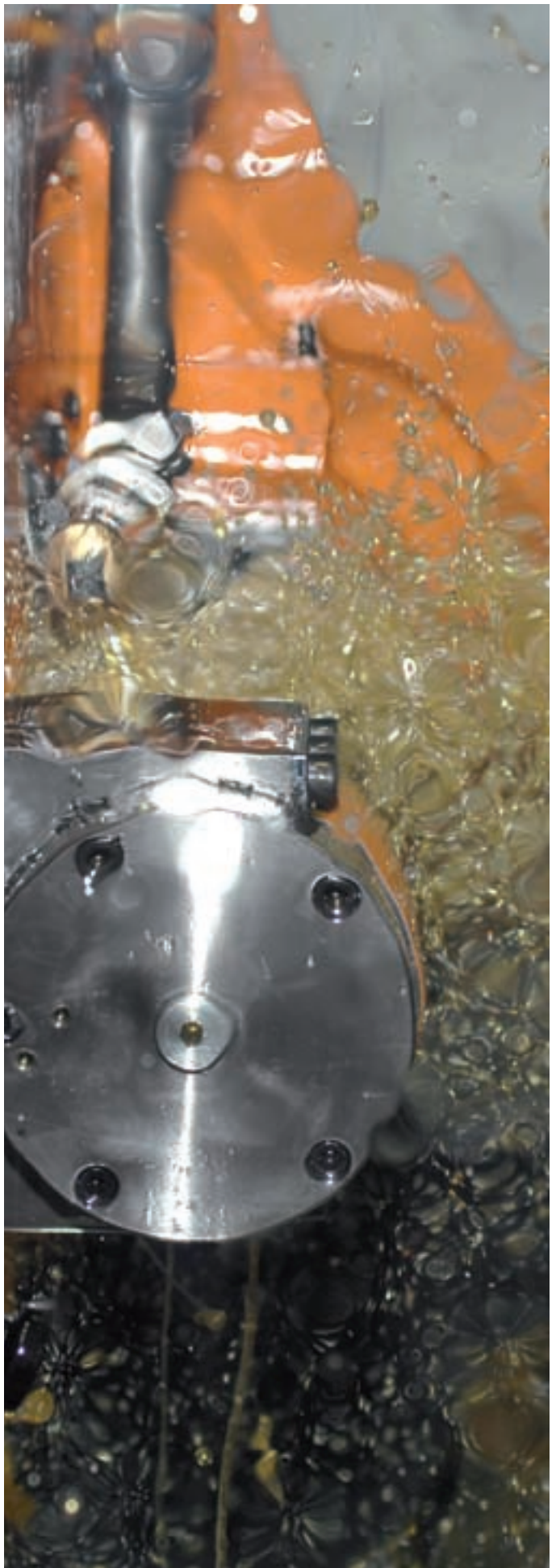

Speed sensor

The M series motors can be fitted with an induction type speed sensor, to measure rotating speed and also direction of rotation.

This accessory may only be used on motors which are suitably adapted to take it (see order code system on page 6, parameter no. 7).

HYDRO LEDUC reference: 090244.

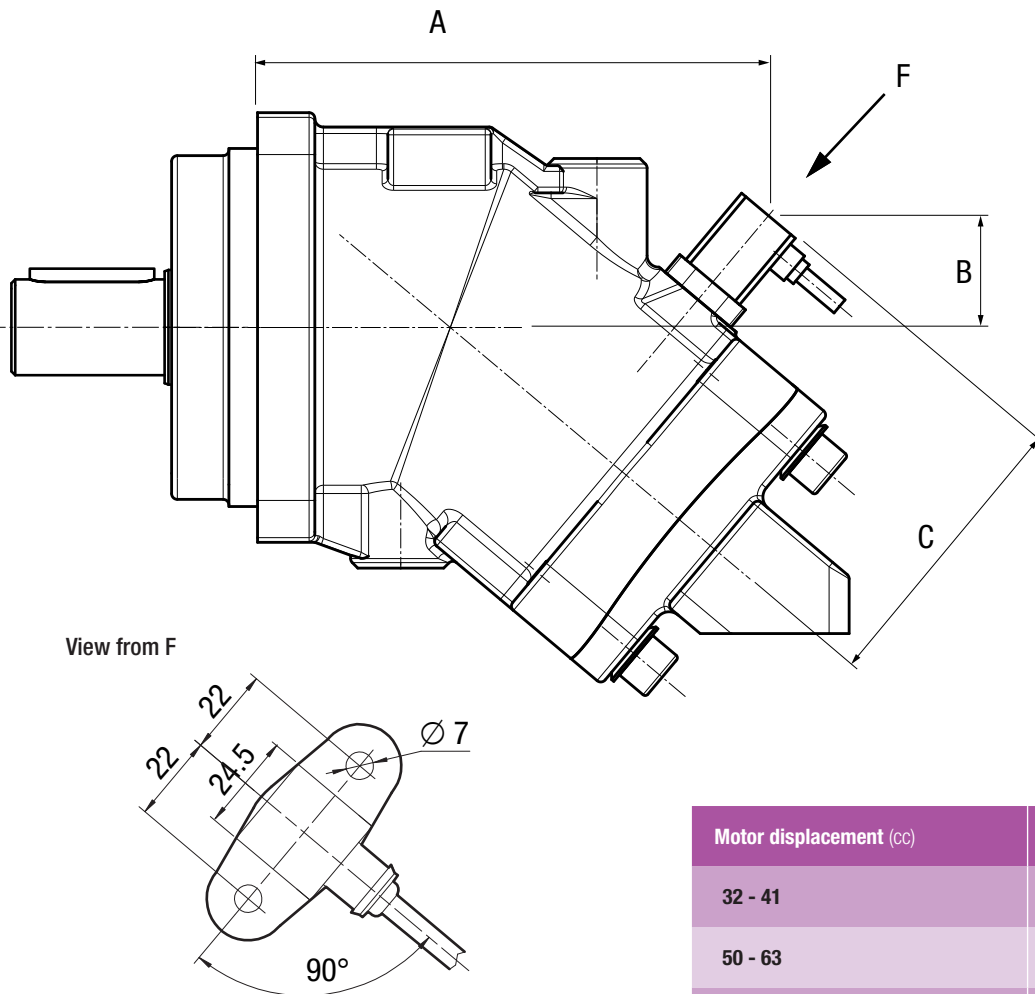

Motor displacement (cc)	A (mm)	B (mm)	C (mm)
32 - 41	161.5	41.6	93.8
50 - 63	178.4	39	101.3
80 - 90 - 108	200.2	38.5	106.3

Note: maximum tightening torque = 50 N.m
For further information, please contact us.

Technical data for the sensor:

Rated voltage	12 and 24 V DC
Residual ondulation	max \pm 2 V DC
Supply current	8...32 V DC
Current consumption	maximum 33mA at 24 V DC
Output frequency	2 Hz...6kHz
Protection type	IP 67 and IP 69 k
Operating temperature	-40°C...+125°C
Storage temperature	-55°C...+125°C
Weight	around 95 g

■ HYDRO LEDUC motors are certified ATEX.

As standard, all HYDRO LEDUC motors are classed in Group II category 2 **D T4**.

On request, motors may be supplied for:

- Group II category **2G**;
- Group II category **D T4**.

In these cases, the motors are not painted and are open to risk of corrosion.

Explanation of the different groups:

- **group II category 2** means it is possible to operate in an ATEX **1** zone (probable gas atmosphere) or ATEX **21** zone (probable dusty atmosphere).
- **G** = may operate in a gas zone.
- **D** = may operate in a dusty atmosphere.
- **T4** : maximum surface temperature of 135°C.

■ Precautions regarding ATEX

The operating temperatures of the motors must be guaranteed by the end user.

Check all parts connected to the motor for conformity with ATEX.

■ Markings on motors

Example of ATEX marking on motors:

CE  **II 2 D c T4 (135°C) HL 1**

If you have different requirements, please contact us.



1

2

3

4

- 1 Dimensional control of M motor housing
- 2 Assembly of M motor
- 3 Spline cutting (shaft)
- 4 MSI motors

Installation and start-up M series motors

■ Maximizing service life of bearings

In cases where there is a radial force on motor shaft, keeping the direction of that force within the shaded areas shown below will improve service life of the motor.

For acceptable radial and axial forces, see page 4.

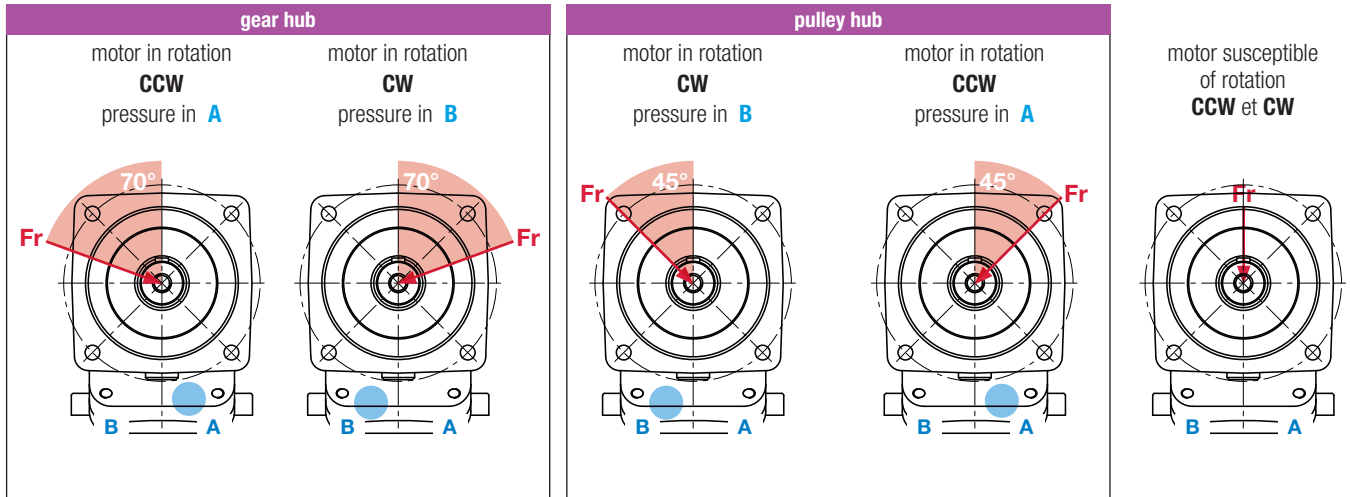

■ Mounting position of motors

HYDRO LEDUC motors can be used in any position.

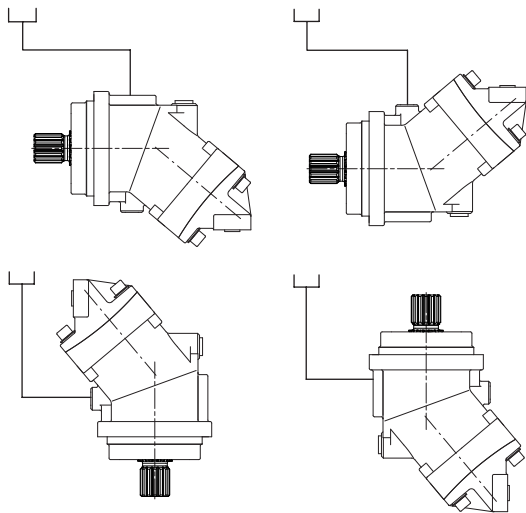

In installations where the position of the motor (H) is above the tank for the drain return, be sure the drain line is always submerged in fluid.

If this is not the case, it is necessary to add a check valve on the drain line following the figure below.

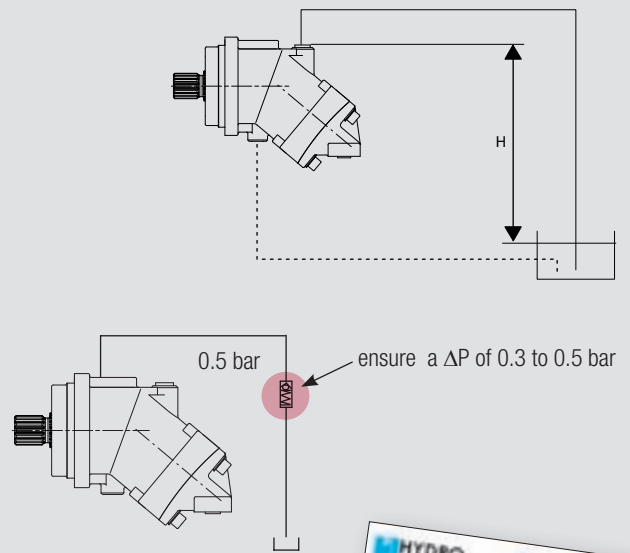

■ Operating conditions

See page 2.

■ Instructions for use

Each motor is supplied with an instruction leaflet, also available via e-mail on request mail@hydroleduc.com.



other product lines

piston pumps for trucks

HYDRO LEDUC offers 3 ranges of piston pumps perfectly suited to all truck, construction equipment, and PTO-mount applications.

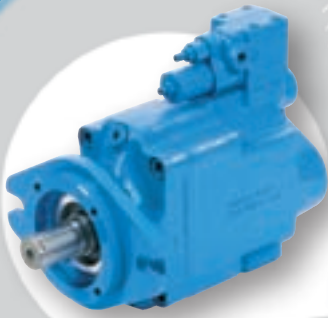

**DELTA
SAE**

Industrial applications

Variable displacement pumps with Load Sensing control, pressure compensation or other control device. Capable of operating at high pressure, in a small space envelope. SAE shafts and flanges.

TXV

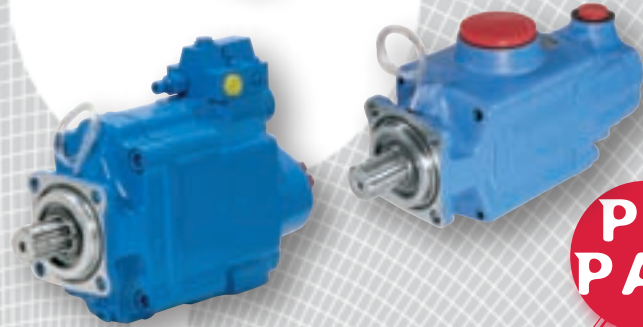

**PA
PAC**

micro-hydraulics

This is a field of exceptional HYDRO LEDUC know-how:

- axial and radial piston pumps, of fixed and variable displacement,
- axial piston micro-hydraulic motors,
- micro-hydraulic units incorporating pump, electric motors, valving, controls, etc.

To users of hydraulic components which have to be housed in extremely small spaces, HYDRO LEDUC offers complete, original and reliable solutions for even the most difficult environments.



hydro-pneumatical accumulators

Bladder, diaphragm and piston accumulators. Spherical and cylindrical accumulators. Volume capacities from 20 cl to 50 litres. Pressures up to 500 bar. Accessories for use with hydraulic accumulators.

**we are passionate
about hydraulics...**

**HYDRO
LEDUC**

A dedicated R&D team means HYDRO LEDUC is able to adapt or create products to meet specific customer requirements. Working in close cooperation with the decision-making teams of its customers, HYDRO LEDUC optimises proposals based on the specifications submitted.

A passion for hydraulics

HYDRO LEDUC

Head Office & Factory
BP 9 - F-54122 AZERAILLES (FRANCE)
Tél. +33 (0)3 83 76 77 40
Fax +33 (0)3 83 75 21 58

HYDRO LEDUC GmbH

Haselwander Str. 5
D-77746 SCHUTTERWALD (DEUTSCHLAND)
Tel. +49 (0) 781-9482590
Fax +49 (0) 781-9482592

HYDRO LEDUC L.P.

14515 Briar Hills Parkway - Suite 116
HOUSTON, TEXAS 77077 (USA)
Tel. +1 281 679 9654
Fax +1 281 596 0903



Complets catalogues available at:
www.hydroleduc.com



HYDRO LEDUC

SAS with capital of 4 065 000 euros

Siret 319 027 421 00019

RC Nancy B 319 027 421

mail@hydroleduc.com